

Dynamic Bend & Torsion Card Tester



**Tests A axis,
B axis and Torsion
Simultaneously**

Features and Benefits

- Tests up to 6 times faster than competing models.
- Tests plastic ISO standard cards 0.25mm to 1.2mm thick.
- Optional capability to test other style cards.
- Super clear, scratch resistant (Lexan) safety hood - pauses the jaws when hood opens.
- Heavy duty motor and construction for production testing.
- Includes a counter and controls to run tests for specific numbers of cycles - stopping point 999,999 cycles maximum.
- Easy-to-use control panel allows users to set speed, counters, load and unload positions, jogging for easy card access and many more functions.

**Mastercard CQM
ISO/IEC 7810
ISO/IEC 10373-1
ANSI INCITS 322**

Bend and Torsion Card Testing

Dynamic Bend/Flexure Test

The Q-Card Bend & Torsion Card Tester is compliant with ISO/IEC 10373-1, CQM or ANSI INCITS 322 standards and is factory tested and certified to the specified card deflection dimensions for each standard. Each set of jaws holds the required number of cards per the ISO, CQM or ANSI standards.

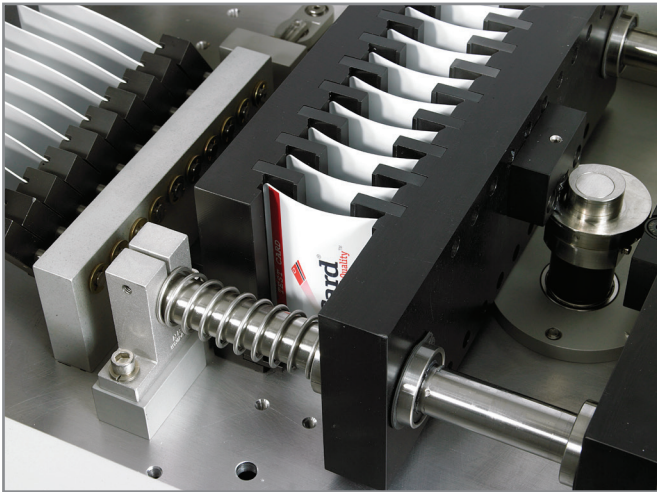

A axis capacity is ten cards.

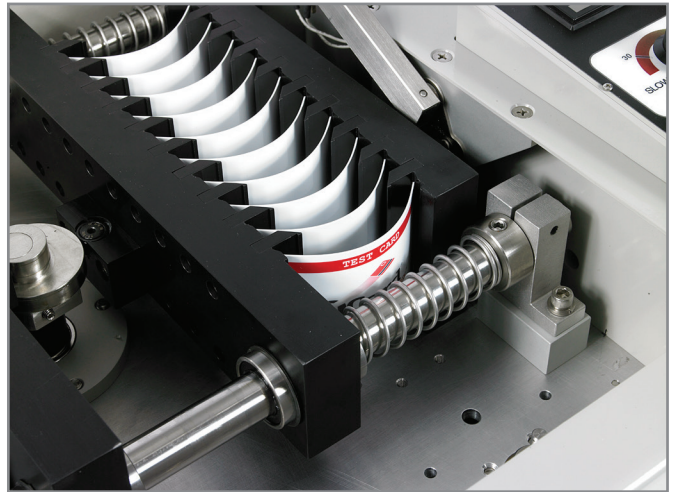

B axis capacity is ten cards.

Card Torsion Test

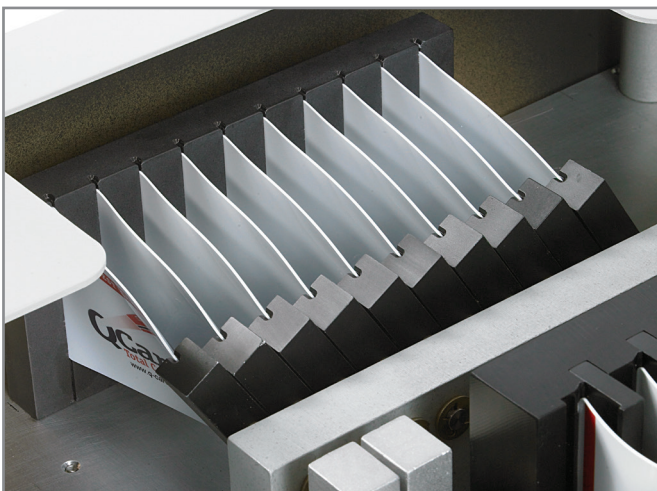

Torsion capacity is ten cards.

Ordering Details

| Part # | Description |
|---------------|--|
| 905951 | ISO/CQM Version (110V) Dynamic Bend and Torsion Card Durability Tester |
| 905952 | ISO/CQM Version (220V) Dynamic Bend and Torsion Card Durability Tester |
| 906303 | ANSI Version (110V) Dynamic Bend and Torsion Card Durability Tester |
| 906304 | ANSI Version (220V) Dynamic Bend and Torsion Card Durability Tester |
| 905951-CAL | ISO/CQM Version (110V) Factory Calibration Service |
| 905952-CAL | ISO/CQM Version (220V) Factory Calibration Service |
| 906303-CAL | ANSI Version (110V) Factory Calibration Service |
| 906304-CAL | ANSI Version (220V) Factory Calibration Service |

Specifications

Electrical

- **USA: 110V / 60HZ / 80 Watt Max**
- **Europe/Asia: 220V / 50Hz / 80 Watt Max**

Weight

- **66 pounds**

Flex Cycle Speed range

- **Adjustable 30 to 60 cycles per minute**

Safety Protection

- **Clear hinged window with open position motor stop switch**
- **Emergency Stop Button for immediate cancellation of operation**

Dimensions

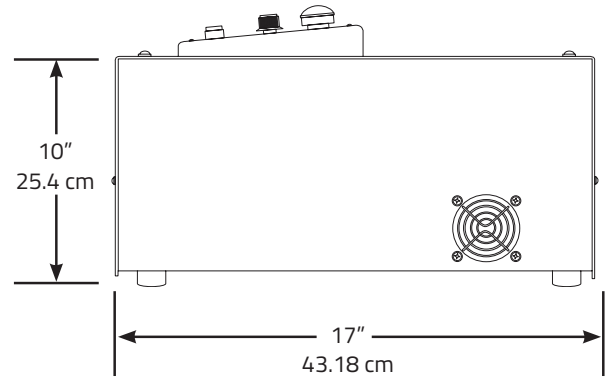
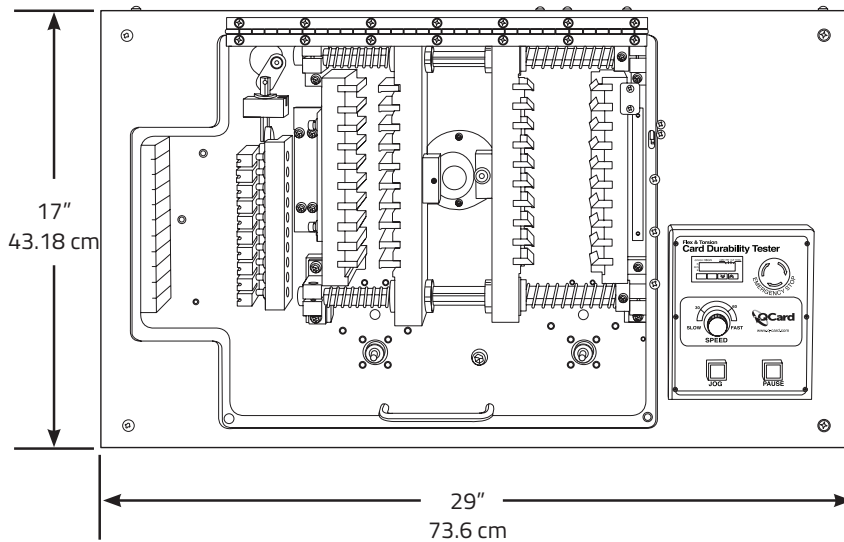

301 Reagan Street
Sunbury PA 17801 USA
Phone 570.286.7447
Fax 570.286.2649
www.q-card.com



800-717-8007